

Tri-Townclub gets shot in arm

Organizational changes within the local Tri Town Track Club will give a giant shot in the arm to the run and jump activity in Richmond Hill.

Commencing today at McKillop Public School, Tri Town will conduct training sessions for Bantam and Midget-age athletes (16 and under) while the older and more experienced competitors will be assimilated into the North York Track

Club in Metro Toronto. Club spokesman, Bob Thompson, told The Liberal, "the marriage of Richmond Hill athletes with North York will make the Toronto, club one of the strongest track and field organizations in Central Region. North York is ranked 8th in Ontario as a track competitor, while Tri-Town is ranked 10th in the province for field

events." Local coach John Monk will head the local bantam-midget program to develop the young athletes for Legion competition in Ontario.

MONEY LACK

"We can now use what little money we have," said Monk, "to develop the young athlete, an area which is the basis of all

good clubs." The move, which came as a surprise to many track and field supporters, was prompted strictly on a monetary consideration.

"We just do not have the financial strength," said a club spokesman, "to maintain the continued development of our Provincial and National athletes, and still conduct grass roots programs for the beginner."

The amalgamation with North York is not new for

the local club. In 1975-76 the two clubs participated as a single entry in the Central Region Track League finishing a respectable third.

In 1979, the addition of the Richmond Hill athletes to North York, will catapult the Metro Team into the top rankings for league competitions against such well established clubs as the Etobicoke Striders, University of Toronto and Uxbridge Optimists.

The Optimist Club

transferred its registered name to Uxbridge after a 1977 dispute with the Ontario Track and Field Association ended with the Scarborough Optimist Track Club withdrawing from future competitions.

TRAIN

Local training on the Wednesday evenings at McKillop School will encourage the Bantam athletes (14 years and under) and the midget athletes (16 years and under) to participate in Ontario Legion com-

petitions which are separate, and a different age category, than the OTFA competitions.

The local training will still bear the name Tri Town Track Club with a guiding body of John Monk, Ron Beresford of Thornhill and Don Murray of Aurora.

Bob Thompson is to coordinate the assimilation of the older athletes into the North York program, as well as acting as the Throwing Coach for the Metro squad.

Local coach Bob Thompson summed up the move by saying, "I'm sorry to see the better athletes moving on but we cannot continue to hold them back because lack of funds, nor can we continue to ignore the development of younger athletes, which is our main reason for being".

Information concerning the North York organization is available from Bob Thompson, 884-4100 or Bill Payne 884-8554.

Town Auto awards

The 1978 Richmond Hill Men's Fastball League champion Town Auto Body held its second annual gala award night recently at the Galaxy Tavern.

A bevy of awards were handed out including a trophy to Steve Whitaker for being the most valuable player, a most improved one to Jim

Henderson, and a special "Boot of the Year" trophy to Dwight Powell for obvious reasons.

Team spokesman Gary Oliver described the "boot" trophy as being "a shoe with a bronze spike imbedded in it. It was something to see. Lovely. He deserved it."

The team, which also won the annual tour-

namment, paid tribute to coach Bob Viverette for his contribution over the year.

Also thanked were team sponsors Sid, Bruce and Dave of Town Auto, Peter of the Record Shop for supplying music for the awards night, and Nick, and George of Galaxy for "putting up with us."

Twin Hills wins 5-4

The Richmond Hill Twin Hills Midget B Rams came up with an impressive 5-4 win over Barrie Saturday night.

The local boys had it all their own way for the first two periods.

They led 2-0 at the end of the first and 4-1 going into the third period.

Barrie fought back hard in that final period

and with 11:44 left managed to tie the score at 4-4.

The game remained scoreless until 12 seconds on the clock when Neil McGregor fired home the winning goal off a good pass by teammate Steve Shannon.

Richmond Hill came up with a good team effort

plus some excellent goaltending by Mike Mulvihill to move back into first place.

Scoring for Richmond Hill were Glen Dunford with two goals and singles to Eric Rockarts, Steve Shannon, Neil McGregor. Assists to Craig McAteer, Eric Rockarts, Steve Shannon and Bill Neilson.

Midgets wallop foe

Thornhill's Minor Midgets went on a scoring spree last week trouncing Newmarket 9-4 and Orillia 10-2 in games played at the Community Centre.

Both contests followed the same pattern; close for two periods and then the Thunderbirds taking advantage of numerous penalties to run away with things.

The Newmarket game saw the score tied 3-3 at the end of the second period. Came the third with the Thunderbirds firing home six goals to the visitors' one.

Steve Tschipper led the way with four goals and two assists. Steve Paul got a pair while Bruce Birchard, Dave Wood and Rob Humphries added singles.

The Orillia game saw Thornhill

ahead 3-2 going into the third period. They took advantage of a parade of Orillia penalties to score seven unanswered goals to win in a walk.

This time the fire power was spread around a little more. Larry Darby had two goals and an assist, Mike Darby scored once and added three assists while Steve Paul, Neil Crebbin and Dave Wood each had a goal and two assists.

Bruce Birchard, Tim Wilson, John Kim and Murray Downs each counted once while Steve Tschipper added four assists.

Besides playing steady hockey the Thunderbirds have settled down to stay away from foolish penalties having broken the habit of retaliating or complaining to officials about calls.

another goal in the third period only to have Richmond Hill scoring three straight goals from Shaw from Scragg; Shaw from Scragg again; and Walton from MacLean and Barton. Sharon managed one more goal.

Keswick jumped into a two goal lead with Richmond Hill's Pipher getting one back in the

Minor Midgets split

The Richmond Hill Minor Midget B's split games recently edging Sharon 4-3 and then losing 5-3 to Keswick.

The Sharon game saw Richmond Hill falling behind midway through the first period before tying the game with Earl scoring from Scragg and McLean.

Sharon came back with

second from Lockerbie and Earl.

Then it was Bynoe scoring in the final period from Pipher and Earl tie the score only to have Keswick get two more goals.

Richmond Hill's Walton got that one back late in the game only to have Keswick score in an empty net.

empty net.

ANNOUNCING THE NEW DATSUN 310. DRIVE A GREAT FRONT-WHEEL DRIVE CAR INTO THE FUTURE.

We know you're still out there. You still get behind the wheel, and invent a destination, simply to enjoy the sensation of driving. The thrill of the road. Do we have a car for you? The new Datsun 310. A new front wheel drive automobile with so many up front advantages, it's difficult to know where to begin. So let's start with the long list of standard features,



such as a split fold-down rear seat—and exciting options, like a 4-speaker stereo. The driver's seat has never been more commanding. Most of the hand controls are stalk-mounted on the steering column. For greater visibility

there's 307.5° of tinted glass all round. And in the 310 Hatchback Sedan, there's even a remote control for



the rear side windows. Few front wheel drive cars out-manoeuvre the 310. It turns in only 31.5 feet with exceptional

power-to-weight. With rack and pinion steering, a fully independent suspension and steel-belted radials, this is performance that will impress even perfection-

ists like you. Inside, the new 310 is a beautifully appointed, roomy and comfortable car with brushed cloth upholstery, colour-matched decor. The ride is quiet with a bi-level flow-thru

ventilation system for maximum comfort. The 310 delivers a great gas economy of 7.1 litres per 100

kilometres.* And the confidence that comes from knowing that only Datsun dares to provide a full 6-year rust protection plan at no extra charge.

So you can go on driving for the love of it. In fact, everything about the 310 has to make you lovers of driving feel good. After all, this new car was built especially for

you. And here you were beginning to think you were an endangered species.

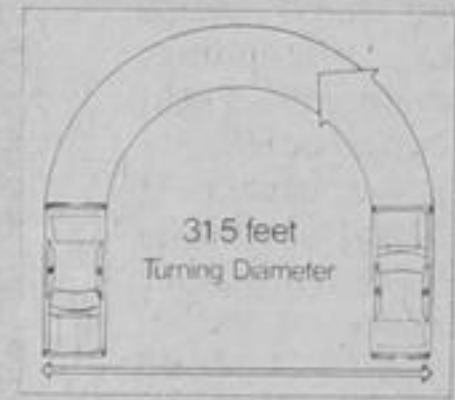

THERE'S MORE FUTURE IN A DATSUN.



210-310-510-SPORTRUCK-200 SX-280 ZX

THE NEW FRONT-WHEEL DRIVE DATSUN 310. FOR PEOPLE WHO STILL LOVE TO DRIVE.



THE NEW

310. THERE'S MORE FUTURE IN A DATSUN.

*Based on lab tests, using approved Transport Canada methods. Actual consumption will vary. Urban winter consumption will be significantly greater. Consult the 1979 Transport Canada Guide for details. Watch the Datsun 310 University Championships on CTV's "Wide World of Sports," January 27, February 24 and March 31, 1979.



PUBLIC HEARING

WEDNESDAY, JANUARY 17, 1979, 8:00 P.M.
COUNCIL CHAMBERS, MUNICIPAL BUILDING, BUTTENVILLE

The Public Hearing will be held by the Planning Committee of the Council of the Town of Markham to consider a Secondary Plan for the South Don Mills Industrial Planning District (Planning District No. 11).

The subject lands are located between Highway 404 on the west and Warden Avenue on the east, and between Steeles Avenue on the south and C.N.R. (Toronto By-pass) on the north. The lands consist of approximately 448 hectares (1108 acres) and are designated Industrial in the approved Official Plan of the Markham Planning Area.

The Secondary Plan has been prepared in accordance with the provisions of Section 8.2 of the Official Plan. The purpose of this Secondary Plan is to establish a detailed land use plan with a basic framework of internal roads, and to establish more detailed policies for the development of the area.

You are invited to attend the Hearing and to state your support of or objection to the proposed Secondary Plan. Should you be unable to attend, written submissions will be received up to the time of the Hearing.

The proposed Secondary Plan, the Official Plan and existing land use maps may be examined at the office of the Planning Department.

Dated December 28, 1978

T. Gove, Chairman,
Planning Committee

T. M. Januszewski,
Planning Director

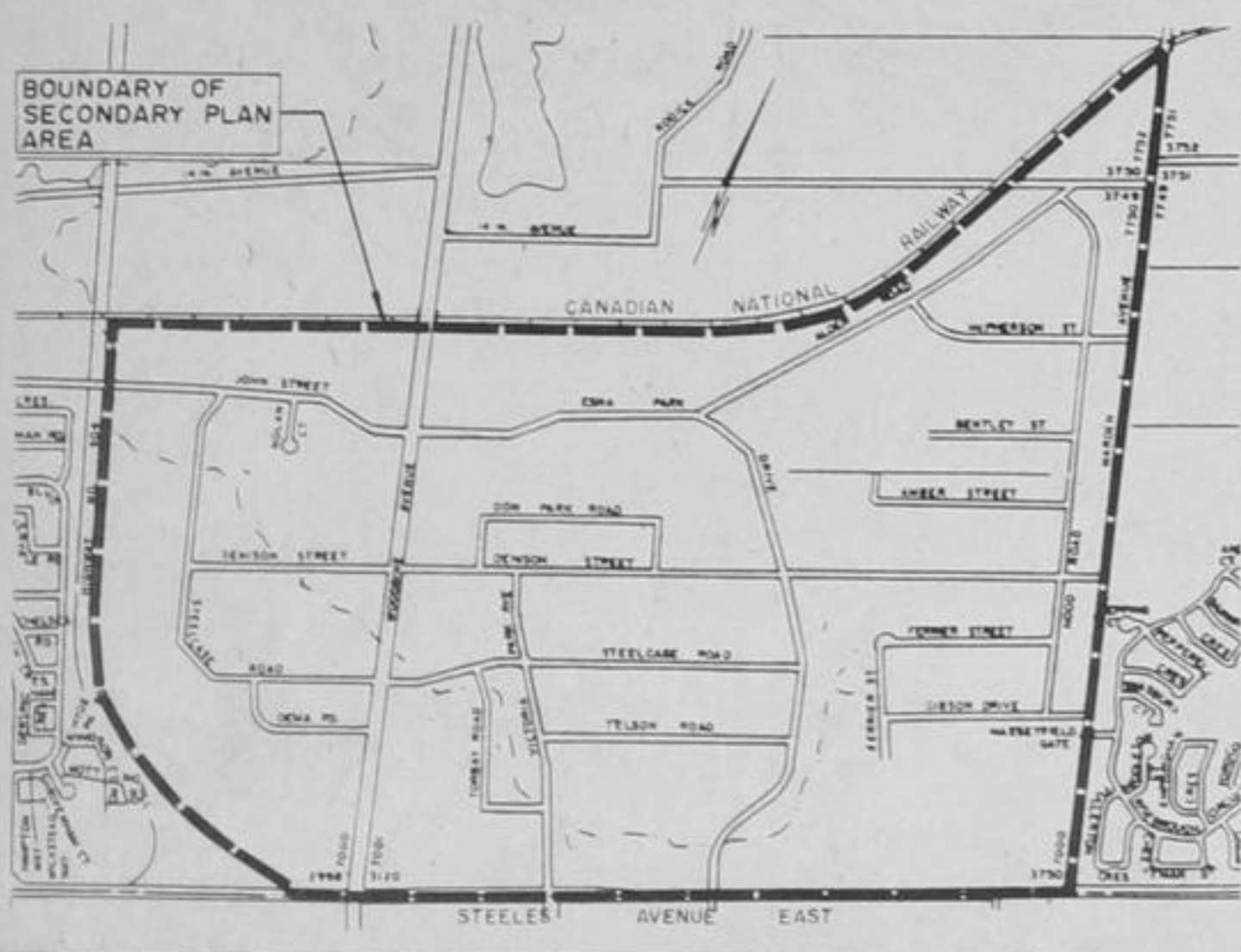

RICHMOND HILL DATSUN LTD.
10427 YONGE STREET
RICHMOND HILL
884-3300