

BEST TENT VALUES ON EARTH

WE ARE SURE!

COMPARE OUR PRICES!

Family-size - Sleeps 4 adults!
'CAMPANI IV'

68.99
WITH POLES PEGS

Built-in 1-piece rubberized (fibre-supported vinyl) floor!

Happy holidays ahead in this! Roomy 8 x 7 x 6-ft tent with zippered door, bug screens, back window with outside tie storm flap, tie-back door curtains. And that 'Molino' floor!

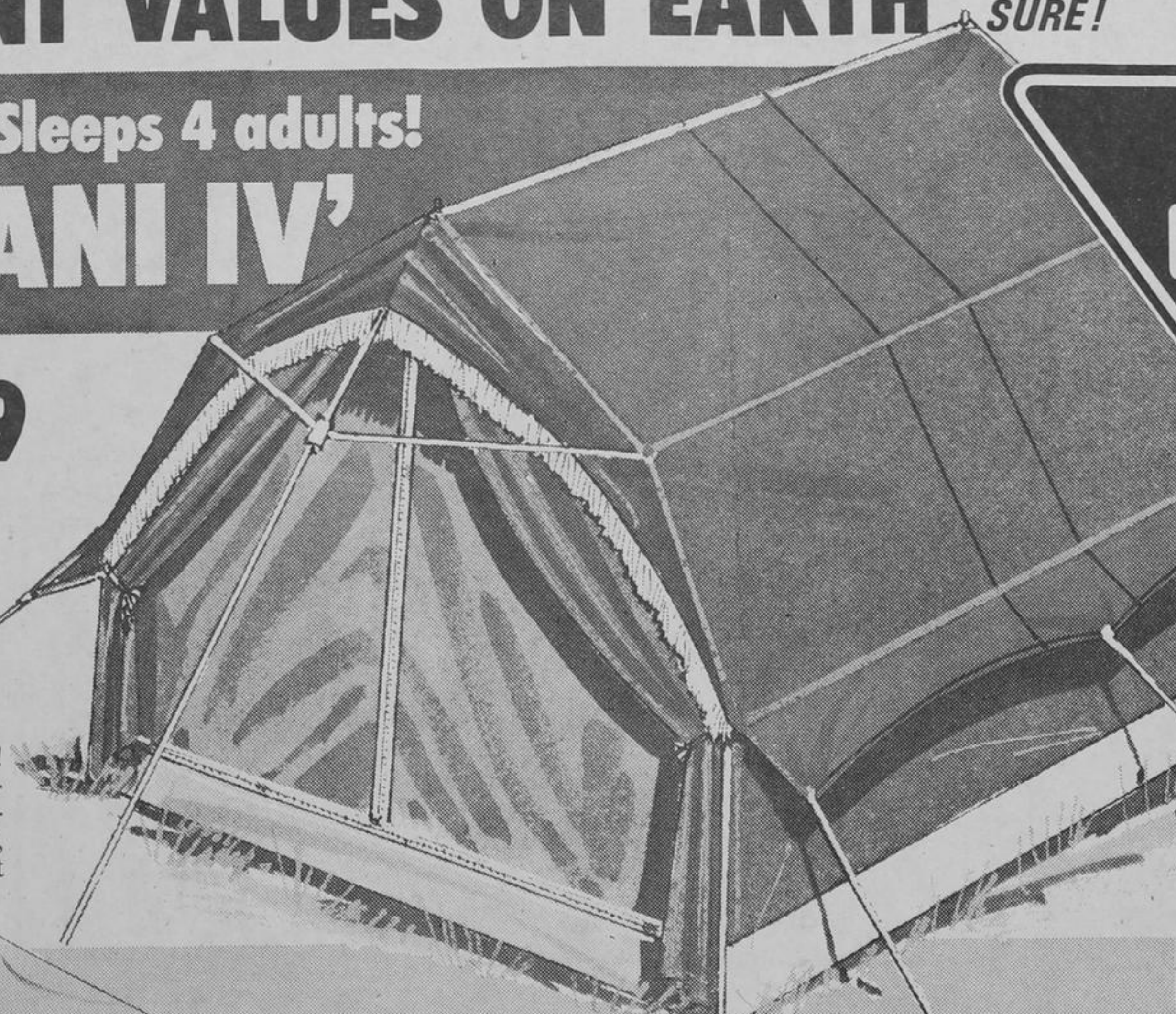

CANADIAN TIRE

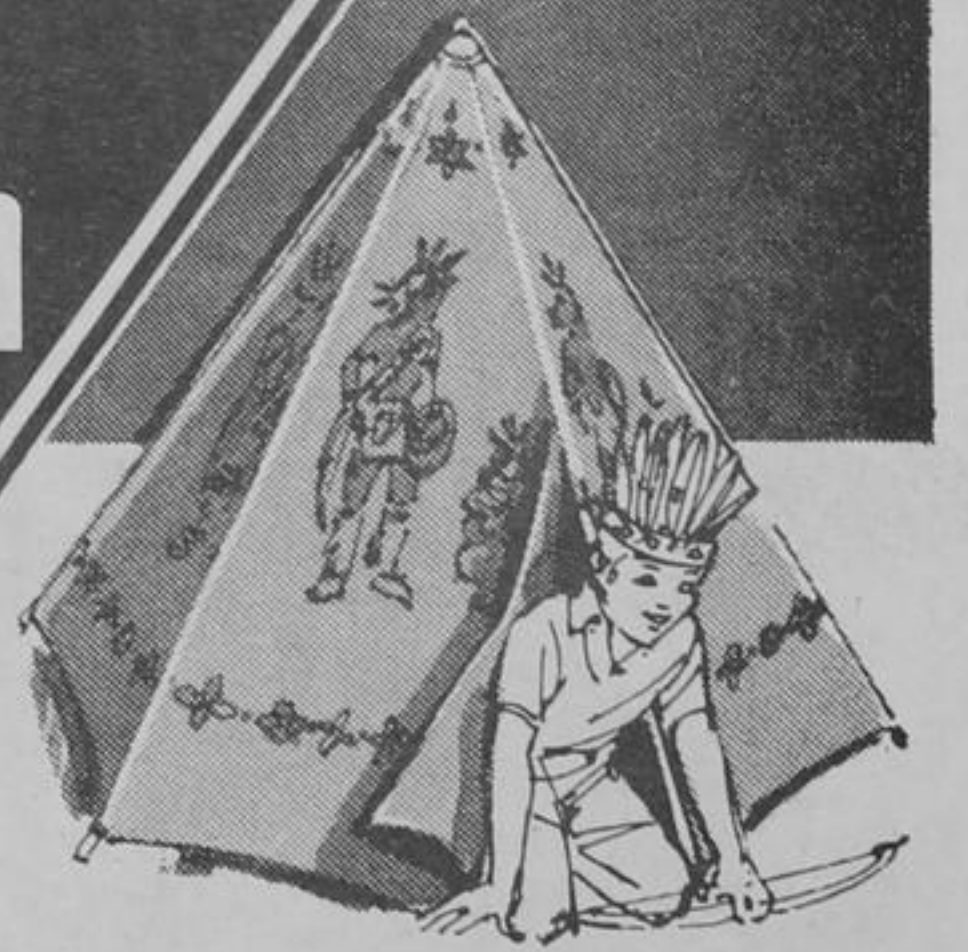

FOR YOUR LITTLE INDIANS
'BIG CHIEF' TENT
8.77

Wigam-style shelter for backyard fun! Colorful Indian motifs screen-printed on sturdy Egyptian cotton. Water-repellent. 5 x 5-foot.



TENT WATERPROOFING
For tents, tarps. 20-oz aerosol. . . . **1.99**

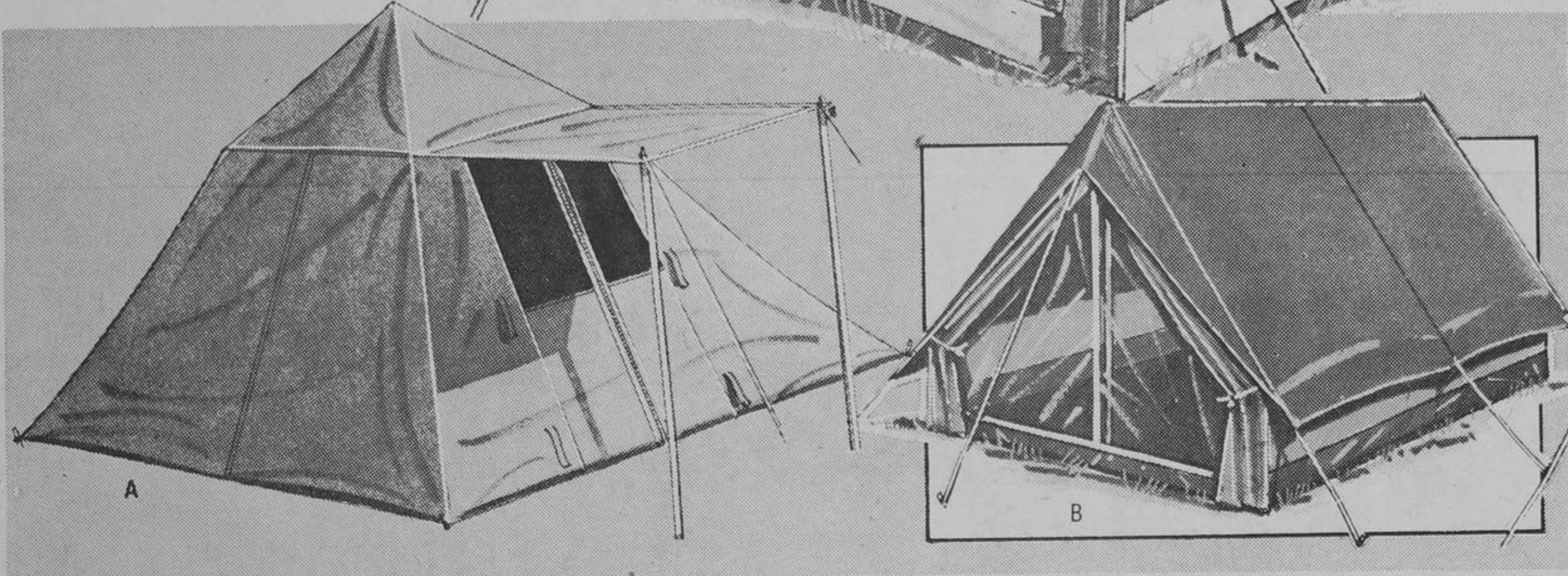

Sleeps 3 easily!

A. Standard Tourist Tent

Popular size—and price! Zippered Dutch door; outside storm flap; sewn-in floor. Full-width canopy. Abt. 9 x 9 x 6 1/2-ft.

43.95

Weights 12-lbs! With Carry Bag!

B. 3-Man Travel Tent

Firm lightweight Egyptian cotton with polyethylene floor. Polyester front screen, back vent. Size abt. 7 x 6 x 5'4" high.

53.99

About 9 x 9 x 7-Foot—Sleeps 3

C. Outside-Frame Tent

Dependable tourist tent with large full-width canopy, zippered Dutch door, outside storm flap and sewn-in flooring.

53.99

SUN CANOPY or WIND BREAK

Stands firm on 8 poles with pegs and guys
About 12 ft. by 10 ft.

765219

\$31.99

COMMANDO LIGHT WEIGHT WATER-REPELLENT

Egyptian Cotton Tent
Poles and Pegs
Suitable For 2 Persons
About 5 ft. by 5ft., 3ft. height with guys

765003

\$9.99

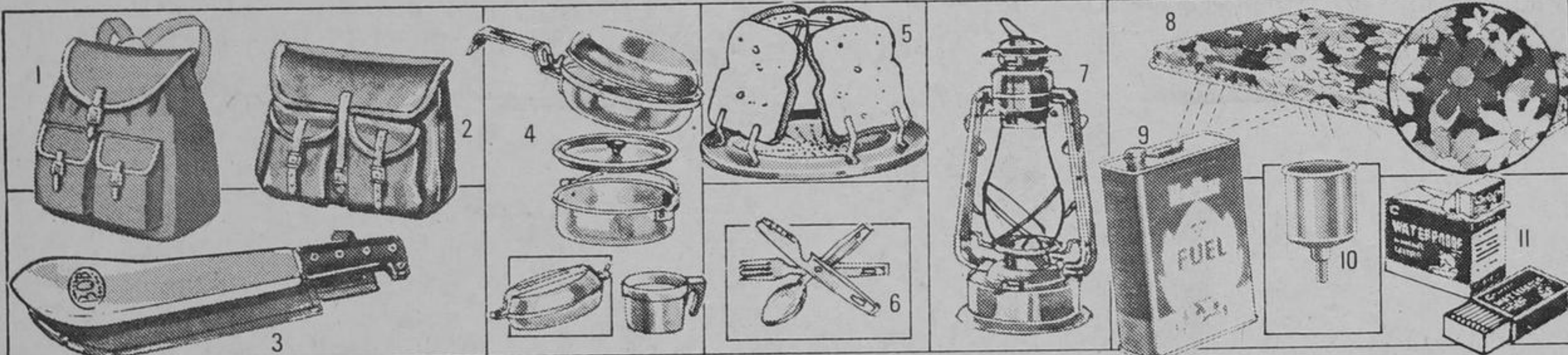

- 1. QUEBEC-STYLE KNAPSACK
Sturdy duck straps. 2 pockets. 16 x 18" **7.99**
- 2. 'ACME' DUCK HAVERSACK
Adjustable straps. Snap-out lining. **6.99**
- 3. BOLO MACHETE and SHLATH
Heavy gauge steel with plastic handle. **4.29**

- 4. 5-Pc. ALUMINUM COOK SET
Nesting set of fry-pan, pot and lid, cup and dish. Non-rust, light. **2.49**
- 5. 4-SLICE CAMP TOASTER
Fold-up holders. 9" diam. Non-rust wires. **.63**
- 6. KNIFE/FORK/SPOON
Stainless. On clip. **.95**

- 7. KEROSENE HURRICANE LAMP
A 9 1/2" high emergency light for camp, cottage. Red enameled metal, Glass chimney, wick. **2.49**
- 8. VINYL PICNIC CLOTH
Colorful washable print table cloth about 32 1/2 x 74". Elastic loops. **2.49**

- 9. MOR-HEAT TENT-HEATER FUEL
For catalytic; Coleman stoves. 40-ozs **.59**
- 10. FILTER STOVE FUNNEL
For use with camp-stove fuel. Standard **1.10**
- 11. COGLANS SAFETY MATCHES
Water-proof; lab-tested. 4 boxes (200) **.55**

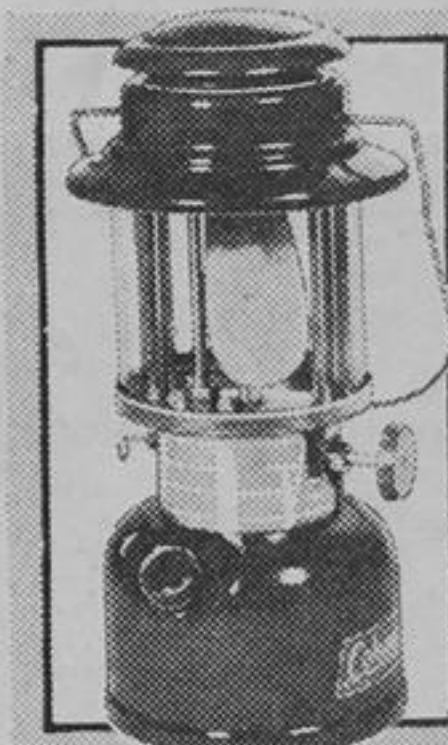

COLEMAN Lantern

18.88

'Sport-rite' holds 1 pt. Naphtha gas for up to 9 hours of illumination.

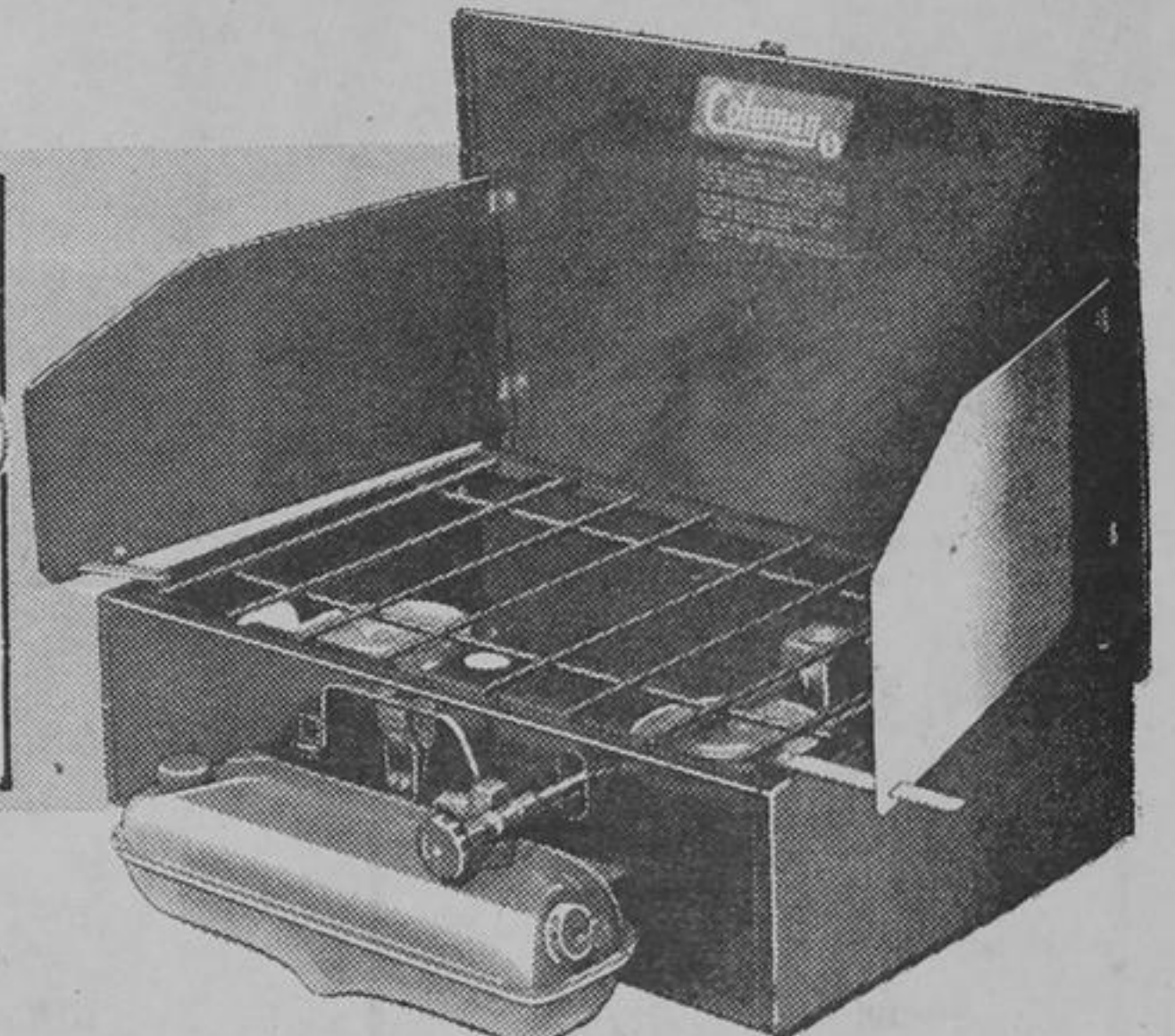

2 BURNER NAPHTHA FUEL Coleman Camp Stove

Instant-light 2-burner stove with protective wind-baffles. 2 pt. capacity. Folds up. **19.88**

COLEMAN FOLDING STEEL STAND

FOR 2 BURNER STOVE
Illustrated above in matching green
762052

\$5.49

CHARCOAL BRIQUETS

5 lb 59c
10 lb \$1.19
20 lb \$2.29

Feature Value STYROFOAM COOLERS

17 1/2 x 12 x 14H **.99** Reg. \$1.35
SPECIAL
23 x 15 x 14H **\$2.89**
23 x 15 x 14H **\$3.79**
WITH BALE HANDLE

"Junior Camper" and "Sportsman" SLEEPING BAGS

30" by 72"
Blue acetate, flannel lining, 760710 **\$9.99**
Acrylic blend filled, 760714 **\$11.99**

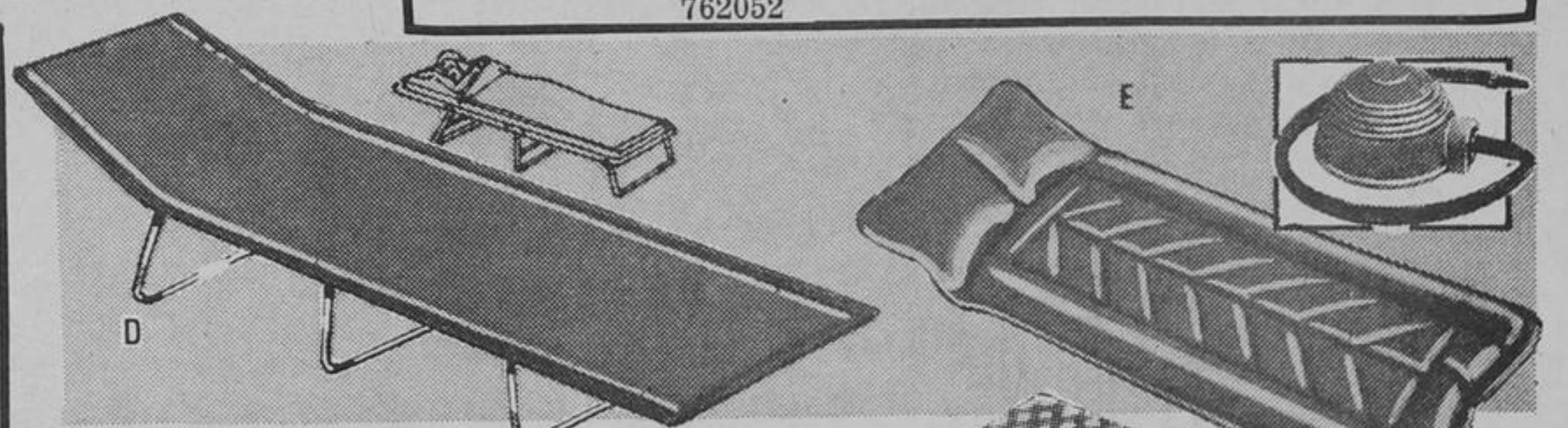

E. REGATTA AIR MATTRESS
Blows up to 30 x 75". Waterproof cotton; rubberized lining. 'I' beam. **8.99**

FOOT AIR-PUMP
Hose with standard fit. **1.69**

G. 'ALGONQUIN' SLEEPING BAG
Blue nylon shell; plaid flannel lined. Celacloth fill; 100" zipper. 36 x 78" **16.69**

H. 'TALL BOY' SLEEPING BAG
Oversize 36 x 84". Green 100% nylon shell with beige printed flannel lining. 4-lb polyester fill; full zipper. **19.99**

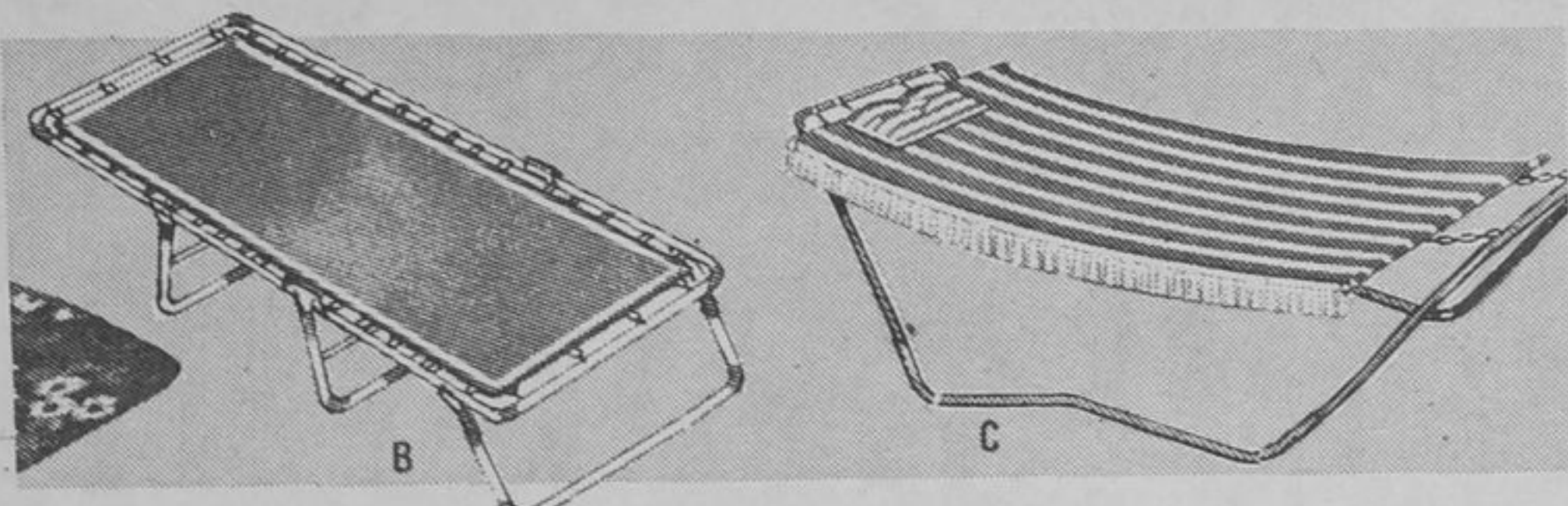

B. SPRING-SUPPORT COT
Extra large 26 x 78" lounge; multi color canvas cover. Adjustable steel frame. 76-1530 **14.49**

C. HAMMOCK & STAND
Firm green duck, white trim. Attached pillow. Anti-tip steel frame. About 34 x 82". **18.44**

D. 'SAFARI' CAMP COT
Tube-steel frame with spring-steel legs. Canvas cover with totebag. 24 x 72". **10.98**

GO FOR THE OUTDOOR COMFORTS NOW with a Canadian Tire CREDIT CARD

Extra Savings with Cash Bonus Coupons on all parts...

or use your convenient Canadian Tire CREDIT CARD



CANADIAN TIRE
ASSOCIATE STORE
10288 Yonge Street, Richmond Hill
Phone 884-1196