

## Check Under the Hood When Serving Yourself

How long has it been since you took a really good look around your car? If you have to pause to remember when you last checked your tires, oil, coolant, battery or other components, you may have put it off too long.

According to Car Care Council, the advent of self-service gas outlets has placed an added burden of responsibility on the car owner. Even most "mini-serve" stations' personnel do not check under the hood, so the repair industry reports a mounting concern about maintenance neglect.

Car Care Council offers the following list of car checks that should be made periodically by the owner, if not by the service dealer:

- **Fluids:** Check engine oil, transmission oil, power steering fluid and coolant; add as needed. Caution: Never remove the radiator pressure cap when the engine is hot.

- **Battery:** Check for corrosion on terminals, a common cause of starting trouble. Check electrolyte level and add water as needed. Another caution: When working near a battery, be sure there is no open flame. Do not smoke. Batteries emit explosive hydrogen gas.

- While the hood is up, take a look at your drive belts and hoses. Frayed or worn belts should be replaced, as should soft, brittle or bulging hoses.

- Take a look at your windshield wipers. The rubber will become brittle with weathering and age and may be worn to a point where wipers smear or streak the glass. How's your supply of washer fluid?

- **Tires:** Invest in a good tire gauge and use it frequently. If you haven't checked tire pressure since summer you're likely to find them underinflated, says Car Care Council. Even a couple of pounds of underinflation can cut tire life by about 10 per cent. Four pounds of underinflation can cost up to three per cent in fuel economy.

- Take a look at the service sticker on your door jamb. Time for a lube job, oil and filter change? One good reason for getting the car on the service station lift is so you or your serviceman can check underneath for leaks; leaking exhaust system parts, leaking shock absorbers, leaking engine or transmission seals. And this gives you an opportunity for another, closer look at your tires.

Finally, as a part of your

MOTORISTS CAN SAVE MONEY ON SELF-SERVE GAS BUT LOSE IT THROUGH NEGLIGENCE. 30% OF ALL DRIVERS SERIOUSLY NEGLECT CAR CHECKS AND MAINTENANCE. FUEL AND IGNITION SYSTEMS SUFFER MOST, BOTH AFFECT GAS MILEAGE.

IF YOU'RE A PUMP-IT-YOUR-SELFER BUT NOT A CHECK-IT-YOURSELFER, GAS UP AT THE FULL-SERVICE PUMPS OCCASIONALLY AND ASK FOR A CHECK-UP.

CCC Car Care Council

periodic inspection program, make a walk-around check of all your lights, including turn signals. If you have no one with you to help check brake lights, you can do it yourself in broad day-light when another car is behind you at an intersection.

Just tap your brake pedal and look for the reflection of your brake lights in his headlights.

Self service fill-ups are great time and money savers, says Car Care Council, so long as you do the whole job yourself.

## J&R AUTO CUSTOM

SALES, SERVICE & RESTORATIONS

- Bonded
- Fully licensed
- Insured
- Equipped for transport trucks

"TOP QUALITY WORK DONE AT REASONABLE AND AFFORDABLE PRICES"

52 Steeles Ave. Bldg. 2  
Unit 8, Milton 876-4375

## Before any of winter's little problems happen —

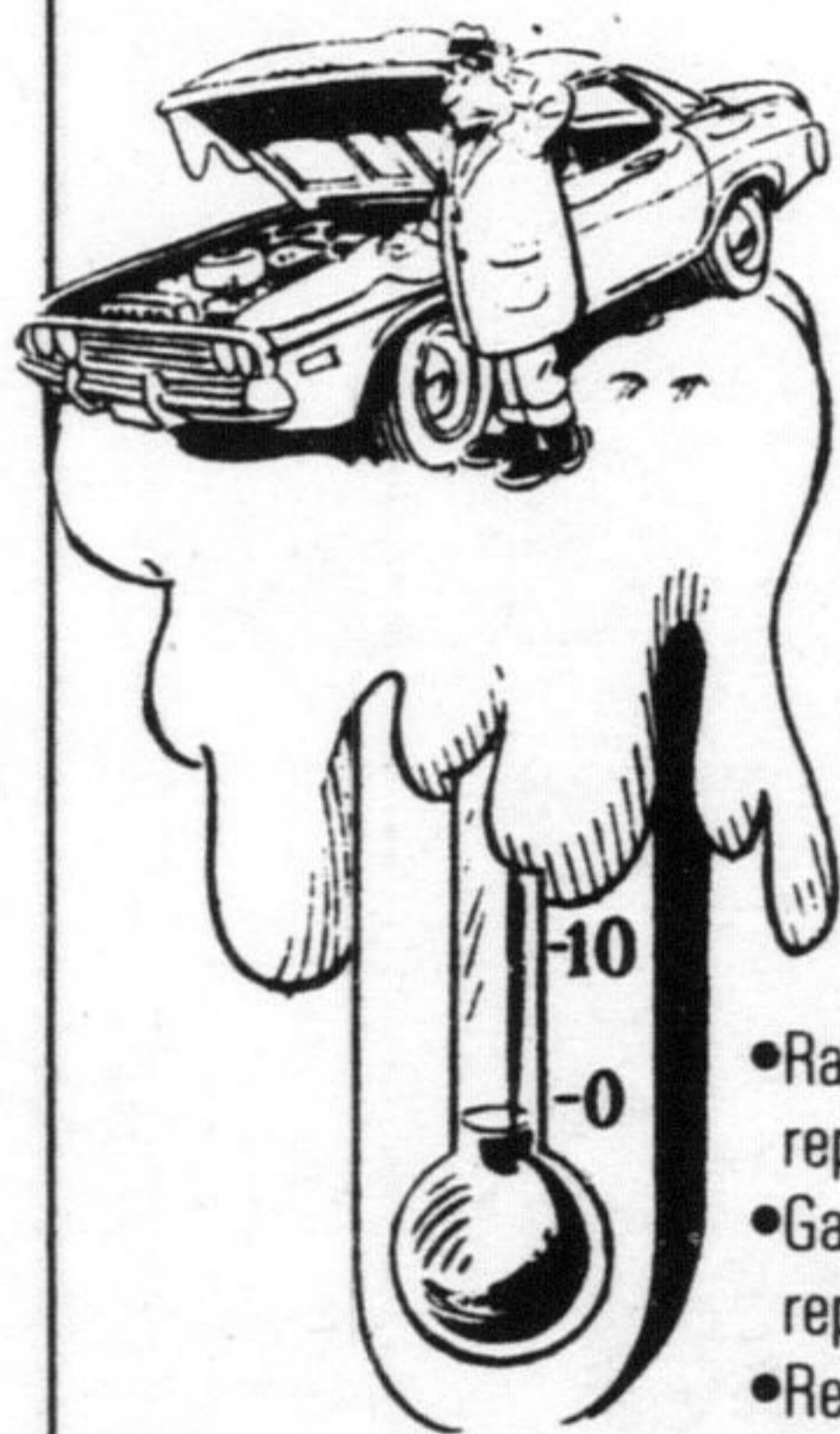

Free inspection of your car's heating & cooling system

- Radiator repairs
- Gas tank repairs
- Re-cored rads
- New complete rads

See Us —

**MILTON RADIATOR**  
878-9646

103 Steeles Ave. No. 7  
(Steeles West of OPP Station)

# BRAKES

## LIFETIME GUARANTEE — SHOES, PADS

### 2 WHEEL DRUM BRAKE SERVICE

Install new linings. Resurface drums. Repack front outer wheel bearings. Inspect wheel cylinders, master cylinder, brake hardware and brake hoses.

**49<sup>95</sup>** MOST CARS

EXPIRES NOVEMBER 30/83

### FRONT DISC BRAKE SERVICE

Install new disc pads. Re-pack front outer bearings. Resurface front rotors. Inspect front calipers, front grease seals, master cylinder, brake hardware and brake hoses.

**74<sup>95</sup>** MOST CARS

EXPIRES NOVEMBER 30/83

### THRUWAY GUARANTEE

The Thruway Guarantee ensures that you will never have to buy brake linings or disc pads for as long as you own your car, when you take advantage of Thruway's BRAKE-thru service.

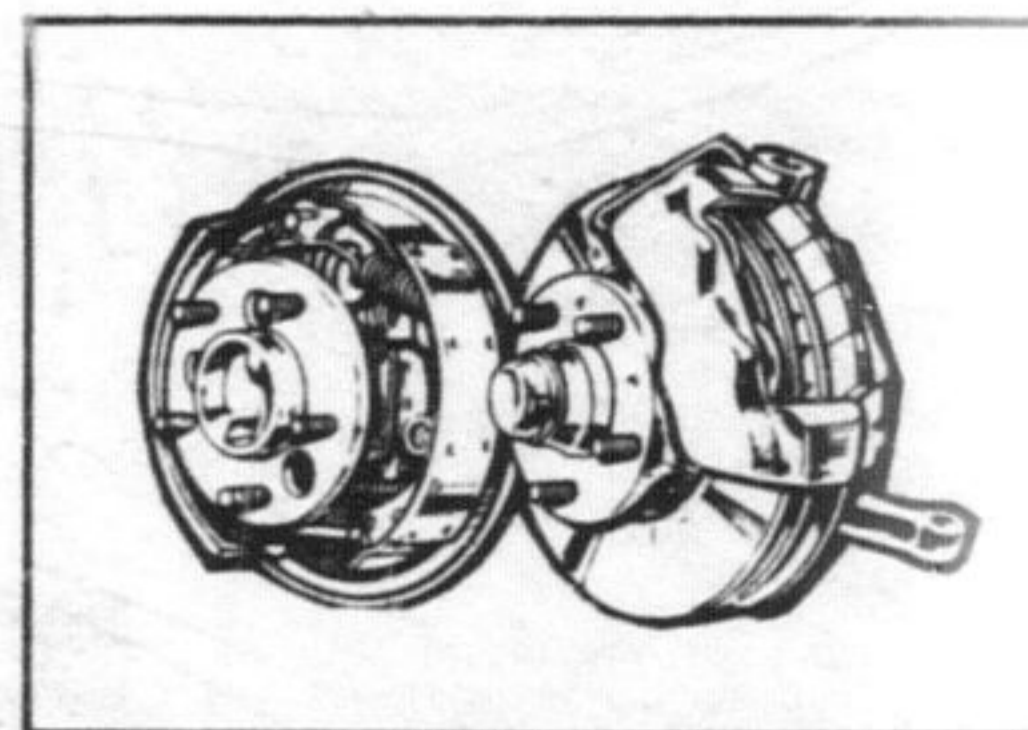

**thruway**  
mufflercentre

701 MAIN ST.  
MILTON  
878-8819

**LUBE IT**

925 Main St.  
(Corner of Thompson & Main)  
878-8595

**OIL SPRAY UNDERCOATING**  
10 MINUTE OIL CHANGE CENTRE  
Receive a voucher for \$5. off an oil change with every oil spray. Includes doors.  
SMALL CARS: \$19.95  
ONLY \$24.95