

Rebel girls fourth

By BILL HUMPHREYS
The GDHS Rebel Girls Gymnastic team finished fourth overall and advanced two individuals onto OFSAA as they competed in the Peel-Halton's earlier this week at Lord Elgin high school in Burlington.

The Rebels were led by Robin Montgomery, who finished third on the senior beam and Caroline Batten who also placed a strong third in the junior uneven bars.

There was a massive total of 28 other schools at the highly competitive meet, the top three placings going to Brampton Centennial, Lester B. Pearson, and Lord Elgin in that order.

The two Rebels will travel to the University of Ottawa on May 5 for the coveted OFSAA championships.

NEVER WON

In the past, the Rebels have never won the Peel-Halton's. Last year the team placed an amazing second, but according to coach Mrs. White, competition is getting stiffer every year.

"The Peel region is not as strong as our Halton region, Brampton's team is not as strong as our's, but because their opposition is not strong, they could send a large amount of athletes to the Peel-Halton's," White said.

This gave Brampton the title, but the quality of gymnasts are better in Halton, such as Burlington which have top quality gymnasts which train with club teams and could be future Olympians, White said.

For next season the Rebels look strong as they only lose two seniors, Montgomery and Tracy Tyndal. Everyone else is back.

Pumping station is sold

Town council has sold Acton's old water pumping station and its site on Main Street South for \$36,250.

Following the receipt of two tenders for the purchase April 11, the property has been sold to Norman Mitchell Developments Ltd. of Brampton.

Coun. Ross Knechtel informed council last Tuesday that the second tender received contained a deposit cheque that had not been certified as required and had also been amended but bore no initial of the person making the change. He added that the Mitchell tender was the lower of the two.

The money received for the property and the small vacant building which still occupies it will be placed in a municipal reserve fund.

FOR THREE YEARS RUNNING FRONT WHEEL DRIVE HAS MADE HONDA CIVIC THE FRONT RUNNER.

In the past ten years there've been a lot of new car concepts that have come and gone. There's also been one that has come and stayed - the Honda Civic. It not only came to Canada and stayed, but it came and drove to the top and stayed. In fact, for the past three years Honda Civic has been the best selling small car in Canada.

YOU DON'T HAVE TO PUSH WHEN YOU'VE GOT PULL.

Undoubtedly, one of the main reasons for Civic's phenomenal success has been its front wheel drive. (Honda was the first to successfully popularize this concept in Canada.) With Honda's front wheel drive

system, the motor and transmission are mounted over the drive wheels, so the weight helps the wheels to bite into the snow or mud and pull the car

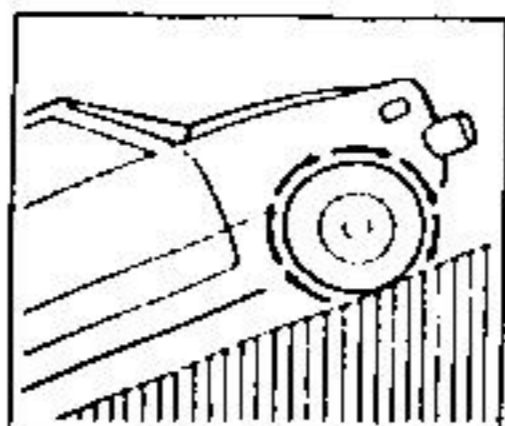

through it. And because the wheels that are pulling the car are the wheels that are steering the car, you also get much better steering control.

A SPECIAL HONDA ANNIVERSARY DESERVES A SPECIAL ANNIVERSARY HONDA.

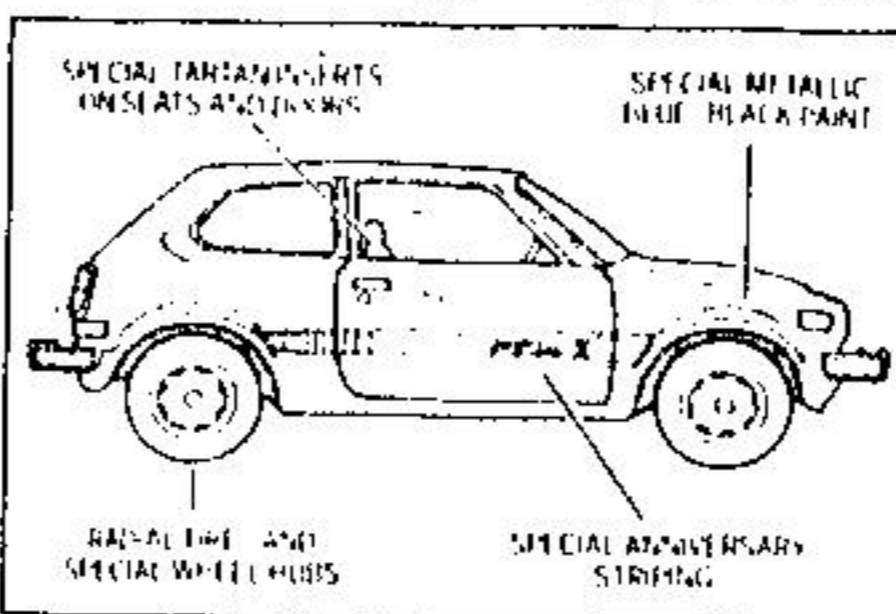

The spring of 1979 marks a rather special time for Honda dealers, because it's the 10th Anniversary of Canadian Honda Motor Ltd. So to help commemorate this

special time, we've developed a limited edition of a very special car - the Honda Special X. The Special X comes with special metallic Blue/Black

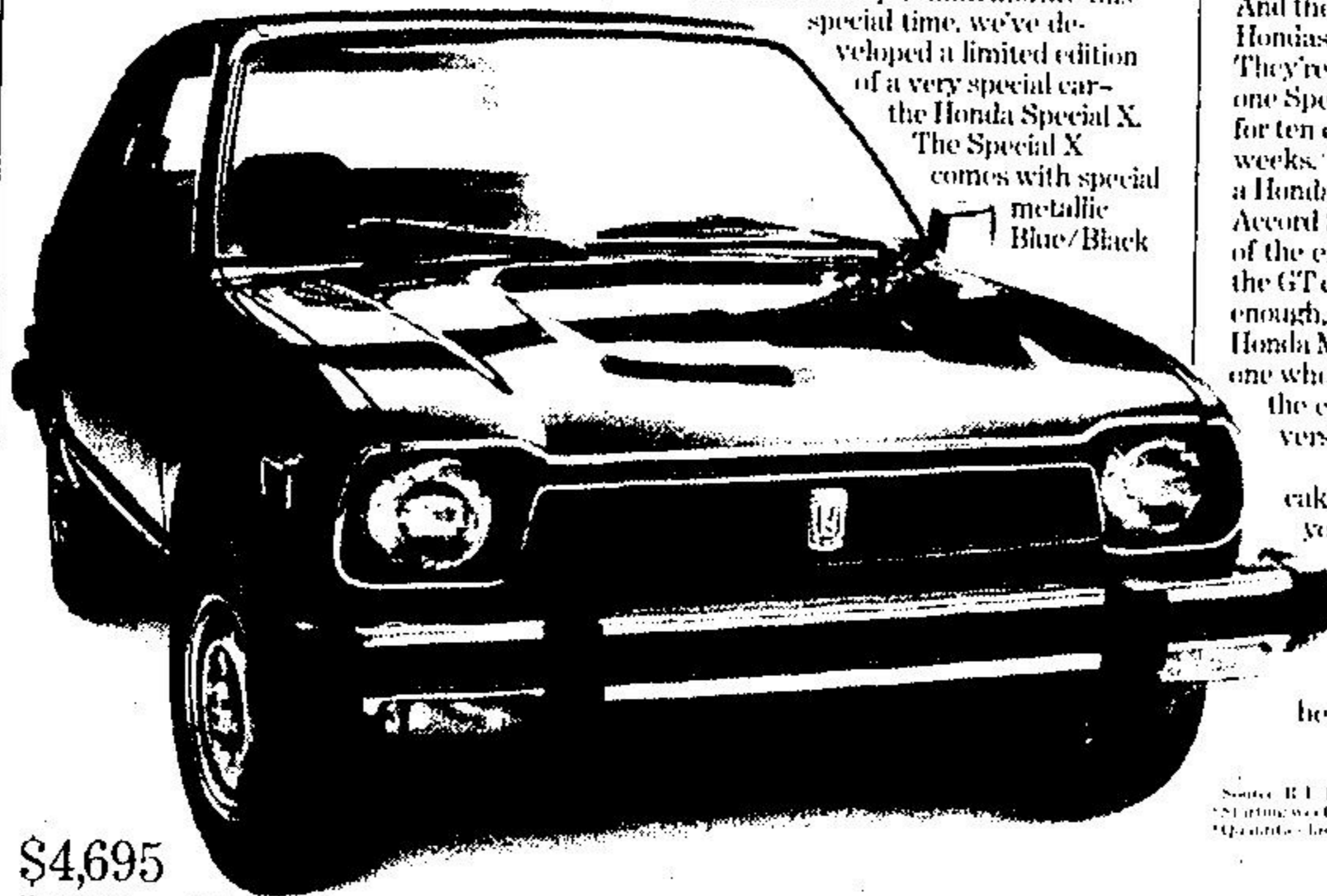

\$4,695

Model shown is suggested price for the 2.0 litre Sedan. Price does not include freight, provincial taxes, licence and delivery charges. Dealer may sell for less.

paint. Special striping. Radial tires. Five-speed transmission. A special tartan cloth insert in the seats and doors. A wood grain steering wheel. And many more Special X features. It also comes with all the other features that have helped make Honda the best selling small car in Canada. Front wheel drive, of course, is standard. As is rack and pinion steering. Fully independent suspension on all four wheels. Power assisted front disc brakes. Reclining front bucket seats. Tinted windows. Carpeting. And a reputation that says it's one of the most enjoyable cars in the world to drive.

TEST DRIVE A HONDA. WIN A HONDA.

To commemorate our 10th Anniversary and thank you for making us so phenomenally successful, Honda dealers are having a celebration. And they're giving Hondas away. They're giving away one Special X a week for ten consecutive weeks. Then they're giving away a Honda Accord Hatchback and a Honda Accord Sedan. They're also giving away one of the exciting new Honda Preludes, the GT car re-thought. And, as if that wasn't enough, they're also giving away 100 Z-50 Honda Mini-Bikes. And to top it all off, everyone who comes in for a test drive during the celebration gets a Honda 10th Anniversary cap!

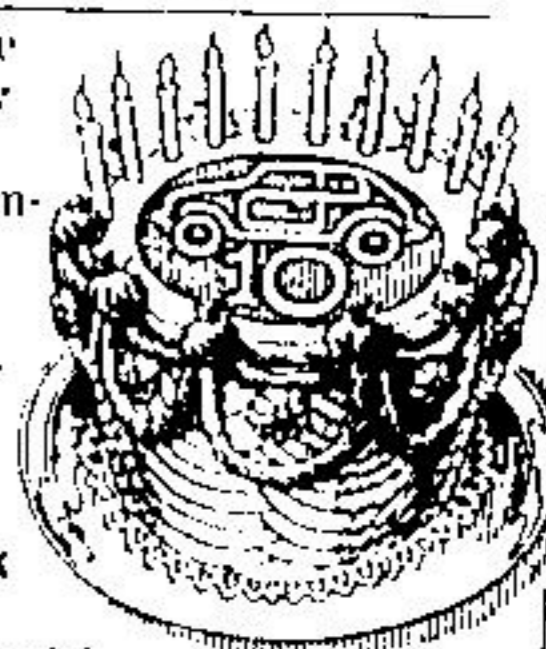

How do you enter? It's a piece of cake. All you have to do is go to your Honda dealer and fill in an entry form. And don't forget to check out the complete line of Hondas available. And take a test drive. You'll see that Honda didn't get to be No. 1 by being second best. Contest ends May 31, 1979.

Special X is a limited edition car. Quantity limited.

TEST DRIVE TO WIN DURING HONDA'S 10TH ANNIVERSARY CELEBRATION.

BAZ MOTORS LIMITED

199 Guelph Street - Georgetown, Ontario L7G 4A8

877-5286 or 676-1813