

Service Specials!!

FREE LUBE WITH THIS AD
OIL & FILTER
 (4 litres of oil max.)
WITH TUNE-UPS
 Offer good on all imports

★ Fully Lic. Mechanics
 ★ Courtesy Cars

21 Point Inspection \$22.95

- Coolant • Air Filter • Fuel Filter • Fan Belts • Battery Check
- C.O. Test • Timing Check • Brake Fluid • Exhaust System • Shocks
- Ball Joints • Tie Rods • Steering • Tire Check • Light Check • Clutch
- Springs • Wipers • Seat Belts • Complete Chassis Check

GOVERNMENT APPROVED INSPECTION STATION

BIG OR SMALL, WE REPAIR ALL
 Offers expire Feb. 28/83

BAZ MOTORS LTD.
 AND
GEORGETOWN HONDA

180-263 GUELPH ST.
 GEORGETOWN
877-5286

WE ARE THE IMPORT EXPERTS



The 1983 Thunderbird is the first example of Ford's giant leap forward in applying aerodynamics to automotive design. Extensive aerodynamic testing in designing the new Thunderbird has given it the lowest air-drag co-efficient among domestic competitors in its class. The new Thunderbird is powered by a Windsor-built 3.8-litre V-6 engine. An optional 2.3-litre EFI-Turbo OHC engine with a five-speed transmission will be introduced later.

Thunderbird, Cougar Ford's future look

By Alex Law
 Thunderbird must be just about the most adaptable car name in the world. It began life about three decades ago as a hot little two-seater and went through seven or eight makeovers to compete in three or four market categories.

And now, teetering on the brink of the big 3-0, T-Bird is back in new form for 1983 1/2 as the sleekest, slipperiest five-seater produced in North America. Made over totally, the new T-Bird is guaranteed to make even the most blasé auto fancier notice that it's new. And radically new at that.

In fact, Ford's T-Bird (and to a lesser extent Mercury's companion Cougar) is the first big step towards the aerodynamic future of the automobile. In the years to come, Ford intends to lead the way in making cars more sleek and fuel-efficient.

Certainly, with T-Bird and Cougar, Ford is on the right track. As good as its immediate ancestor was, the T-Bird that will be unveiled in dealer show rooms during the Toronto Auto Show is quite a bit better.

The most important improvement is on the open road. In handling and performance the new T-Bird and Cougar are well ahead of their ancestors. Indeed, they are well ahead of cars you would expect they might be, and even some you wouldn't. Ford welcomes this comparison as it's out to flog these cars head-to-head with competition like BMW, Buick Riviera, Olds Toronado, Audi, and other noted touring cars, as well as old foes like Buick Regal and Chevrolet Monte Carlo.

And, if the appearance, performance and handling features of the new Ford products were only just close to this higher class competition, the prices for the new North American-built cars rebalances the equation. The stock T-Bird and Cougar carry suggested retail prices of \$11,106 and \$11,327. Those cars come with a flood of standard items and a 3.8-litre V-6 mated with an automatic three-speed with locking torque converter.

A number of attractive options such as better suspensions, keyless entry, articulated seats and, later in the year, a voice alert system, are also available.

With its no-holds-barred approach to an aerodynamic design, T-Bird registers an impressive .35 drag coefficient. Cougar's traditional rear roofline raises its drag coefficient to a still respectable .40.

But the model for real car freaks will be the \$14,344 sticker-priced T-Bird Turbo Coupe. This hot little 2.3-litre overhead cam engine is run by a five-speed stick shift that, combined with a special handling package, makes the turbo T-Bird a performance leader.

New Yorker .

(Continued from C1)

Chrysler is also introducing a prototype for the first front-wheel-drive sports car in North America, the turbo-charged Laser.

The Laser, which will be available in 1984, has a four-cylinder, fuel-injected, 2.2-litre turbo-charged engine and will have a base sticker price of about \$10,000.

Preview of the Prelude

By Alex Law

Buyers eager to see Honda's 1983 Prelude can see it at the Toronto International Auto Show even though its only due in the dealer's showroom in March.

Totally redesigned and sporting a bigger engine and a bigger price tag, the Prelude has been built with aerodynamics in mind. The remarkably low-sloping hood, incorporating retractable rectangular headlights, sweeps down to a massive matte-black bumper and air dam combination. Overall, the car has a very fast, sloped look, and a drag coefficient of .36.

A Honda spokesman estimates the

car will carry a suggested retail price of approximately \$11,500, higher than the '82 Prelude but less than Honda Canada expected.

And while the '82 Prelude relied on 1600 cc to pull it around, the '83 is powered by a transverse-mounted 1829 cc four-cylinder, single overhead cam, 12-valve engine producing 100 horsepower at 5,500 rpm.

Engine response and fuel efficiency are maximized by dual constant-velocity carburetors and a cross-flow cylinder head design, allowing fuel and air to enter from one side of the combustion chamber and to exhaust from the other.

Helping you do it

... your own way

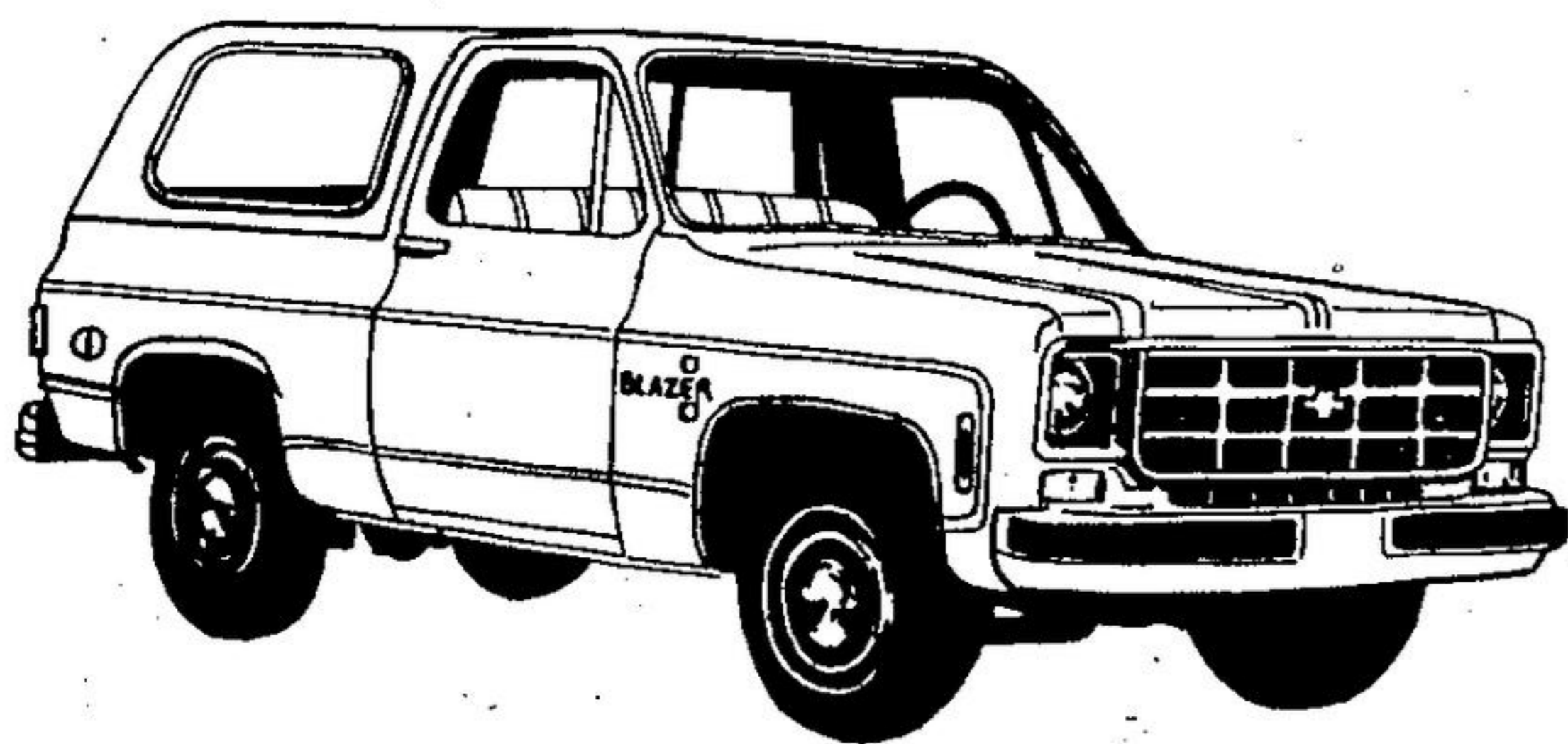

We have a full selection available of replacement body panels in steel and fibreglass.

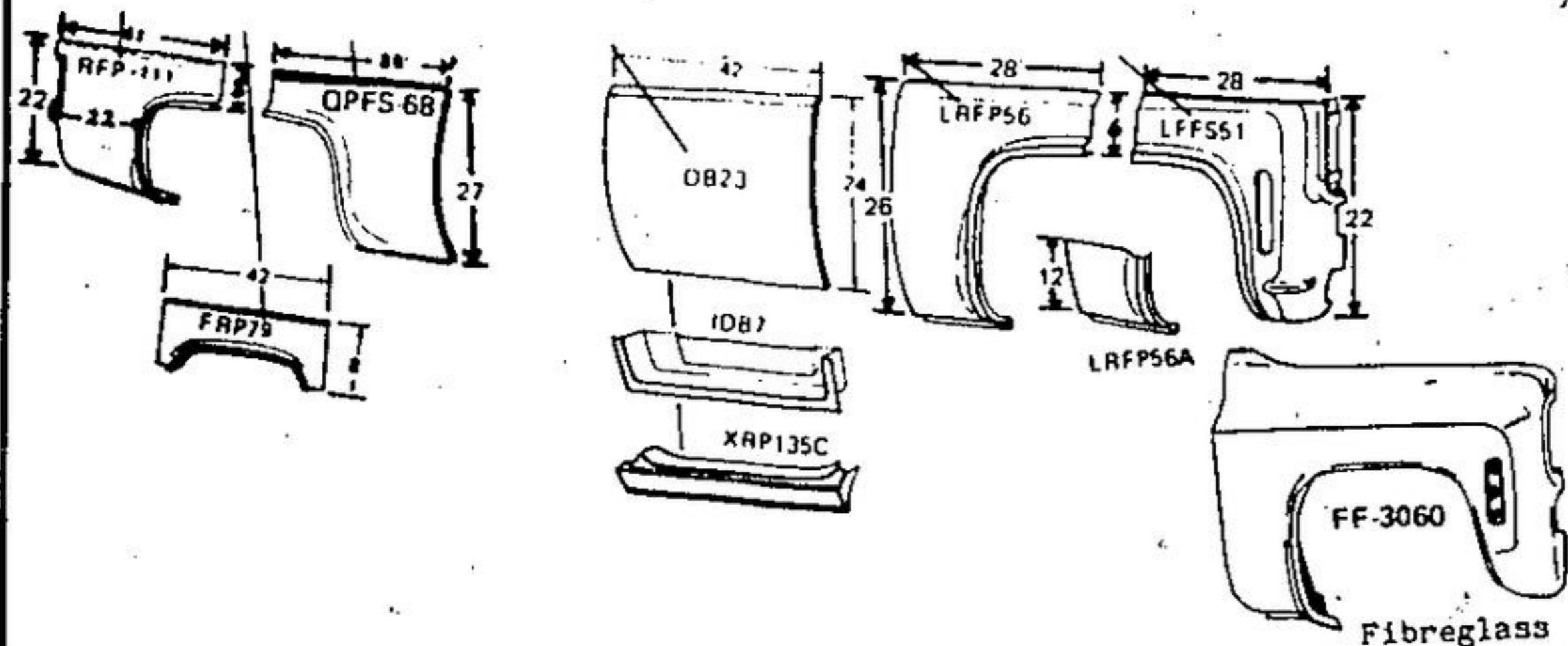

- rechromed bumpers
- Dupont, paint products
- a complete line of auto parts, accessories

For all your wholesale or retail automotive needs

OR

Let an auto body specialist handle your vehicle

Armstrong Collision
 Arnie's Body Shop
 Best Way Auto Shop
 Brampton Collision
 Capital Ford Body Shop

877-5163 Georgetown Coach Works
 877-5720 Halton Hills Collision
 877-2466 Mountainview Collision
 877-1633 Murray Motors Body Shop
 877-5277 One Stop Auto Body

877-1733 Riteway Auto Body
 853-2860 T & G Auto Body
 877-8384 TRA Enterprise
 877-6944 Uptown Collision
 877-1900 Wally's Auto Body

877-8685
 877-8703
 877-0873
 877-9211
 877-7512

Mavalk
 AUTOMOTIVE

your Bumper to Bumper dealer
 13 Armstrong Ave. **877-0143**
 just off Mountainview Rd.

A NEW LOVE AFFAIR
 COMING THURSDAY FEB 17th
THE ALL NEW 1983 THUNDERBIRD
CAPITAL FORD SALES
 361 GUELPH ST
 G T W N

THE PAINT AND REPAIR EXPERTS

DAVE ARMSTRONG SAYS:
 (MANAGER)
LET US ADD A TOUCH OF SPARKLE TO YOUR AUTO
 We'll iron out dents and expertly color match your car for a great new paint finish.

STOP IN TODAY FOR:

- FREE ESTIMATES
- INSURANCE CLAIMS HANDLED QUICKLY
- ALL REPAIRS FULLY GUARANTEED

Uptown Collision
 142 Main St. **877-9211**
 Georgetown